

Tournoi



quiet safety

PREVENTING SKIN INJURIES

JAMES A MCEWEN, PHD, PENG
KEVIN INKPEN, MASC

FOR MAXIMUM SAFETY, TOURNIQUET CUFF PRESSURE AND DURATION SHOULD BE MINIMIZED AND SKIN INTEGRITY UNDER THE CUFF SHOULD BE MAINTAINED.¹ CUFF PRESSURE CAN BE MINIMIZED BY SELECTING THE WIDEST, BEST FITTING CUFF FOR THE CHOSEN LIMB LOCATION^{1,2,3} AND BY SETTING THE CUFF AT THE PATIENT'S LIMB OCCLUSION PRES- SURE (LOP) PLUS A SAFETY MARGIN, TYPICALLY RECOMMENDED TO BE 40-80 MMHG FOR A CUFF SNUGLY APPLIED TO A NORMAL LIMB OF A NORMOTENSIVE PATIENT.² EVEN WHEN CUFF FIT AND PRESSURE ARE IDEAL, HOWEVER, INJURIES TO THE SKIN UNDERNEATH THE CUFF, SUCH AS INDENTATION, REDNESS AND BLISTERING, CAN STILL OCCUR.^{4,5,6}

Stockinette or cotton-cast padding is commonly used between the cuff and the skin to help prevent these injuries. Present recommended practices for the operating room state, “Manufacturers’ instructions may suggest that a soft, wrinkle free padding (eg cotton-cast padding, stockinette) be wrapped smoothly around the limb...” Yet related educational material states, “Do not use cotton-cast padding, sheet padding, Webril, or any other material that may shed loose fibers; lint from these materials can become embedded in the contact closures and reduce their effectiveness.”⁷ Some manufacturers make no specific recommendations about underlying padding, leaving the user with no clear guidance on the best limb protection technique.

Limb protection sleeves of various types have recently been introduced by other disposable cuff manufacturers; for example, one brand is supplied with a four-layer, loose fitting stockinette sleeve, and the user is instructed to “wrap the area with a stockinette sleeve.” In the literature, there is currently no quantitative comparison of the severity of wrinkling and pinching of the skin under different cuff and limb protection combinations, so it is not clear what type of limb protection minimizes the risk of skin damage, and the question of which technique to use remains unanswered. This question particularly concerns operating room staff who are often responsible for tourniquet application.

To answer this question, we have developed a technique of making and analyzing an imprint of the cuff-to-skin interface to quantitatively compare wrinkling and pinching of the skin under various types of padding or limb protection. We have recently described this technique and reported results on pediatric subjects.⁸ In this article, we present the results from multiple trials on five healthy adult volunteers to demonstrate:

- a first brand of disposable cuffs applied directly to the bare skin.
- the same cuffs used with cotton-cast padding.
- a second brand of disposable cuffs with a built-in layer of ‘gel’ padding applied directly to the bare skin.

- a third brand of disposable cuffs used with the stockinette sleeve supplied with each cuff.
- the first brand of cuffs used with tubular elastic material sleeves matched specifically to these cuffs.

Our hypothesis is that some types of cuff/padding combinations will cause substantially less severe wrinkling and pinching of the skin than others.

Method

The University of British Columbia granted ethical approval for this study. To approximate the deformation of the skin surface in contact with the cuff or padding, we placed a layer of modelling clay sheet (Model Magic, Binney & Smith Canada, Lindsay Ontario Canada, extruded through rollers to a uniform 2.5 mm thickness and covered with a single layer of plastic film) on the limb of the subject. An experienced technician applied the limb protection or padding (if used) and cuff ensuring that the overlap of the cuff was positioned over the modelling clay sheet. The cuff was inflated to 200 mmHg for one minute, deflated, and removed. The modelling clay sheet (now imprinted with the texture of the cuff or padding on the top surface and the skin texture on the underside) was removed, allowed to dry, and bonded skin side down to a flat plastic card using double-sided tape. The top surface (cuff/padding imprint) of the mounted mold was then digitized in a 5 mm proximal-distal (PD) by 0.20 mm circumferential grid on a coordinate measuring machine (Picza Pix-3, Roland Digital Group). (See Figure 1a for the resulting image of a typical mold.) The resulting section profiles approximate the circumferential profile of the skin surface at 5 mm PD intervals under the cuff. An area of 95 mm (circumference) by 45 mm (PD, 10 sections spaced at 5 mm intervals) at mid-cuff, including the cuff overlap, was analyzed in all trials.

Wrinkles in the skin surface are defined as a change in height of at least 1 mm with a slope of 0.25 (1 mm height change for every 4 mm of distance along the skin surface) or steeper, lying within a 10 mm circumferential length of skin

Table 1 Cuff and limb protection configurations

CONFIGURATION	DESCRIPTION
Cuff A, Bare	Disposable Cuff A (no limb protection supplied). No limb protection used.
Cuff A, Two layers cast pad	Disposable Cuff A (no limb protection supplied). Two layers of cast padding used.
Cuff B (Gel)	Disposable Cuff B with built-in 'gel' padding. No limb protection used.
Cuff C, Four layer stockinette	Disposable Cuff C. Four-layer stockinette sleeve (as supplied in the sterile package with the cuff) used.
Cuff A, matching Two layer elastic sleeve	Disposable Cuff A (no limb protection supplied). Two layer tubular elastic bandage sleeve (matched to specific tourniquet cuff) used.

Table 2 Wrinkle and pinch maximum height and sum of heights results (mm)

Trial	Cuff A, bare		Cuff A, two layers cast pad		Cuff B (gel)		Cuff C, four-layer stockinette		Cuff A, matching two-layer elastic sleeve	
	MAX	SUM	MAX	SUM	MAX	SUM	MAX	SUM	MAX	SUM
Subject A, L thigh	3.08	122.80	6.23	194.3	3.20	154.3	1.70	18.0	1.45	4.88
Subject A, R thigh	4.68	151.2	3.08	63.5	3.53	85.0	2.50	37.0	0.00	0.00
Subject A, L arm	2.70	173.1	1.78	8.7	6.23	123.0	0.00	0.0	0.00	0.00
Subject B, R thigh	5.18	138.1	2.43	75.7	2.38	44.6	0.00	0.0	0.00	0.00
Subject B, L arm	2.03	24.4	1.63	32.3	2.95	68.6	1.40	3.6	0.00	0.00
Subject C, R thigh	1.63	82.5	2.48	83.6	4.65	69.7	1.65	12.8	0.00	0.00
Subject C, L arm	2.55	134.9	2.10	69.6	3.65	114.5	1.38	3.6	0.00	0.00
Subject D, R thigh	2.20	58.0	1.48	25.4	4.13	80.8	2.15	9.8	0.00	0.00
Subject D, L arm	2.15	67.75	2.15	64.9	3.00	62.4	1.58	13.1	0.00	0.00
Subject E, R thigh	3.93	117.9	3.13	64.7	3.23	43.6	2.58	16.2	0.00	0.00
Subject E, L arm	3.20	76.7	2.90	53.0	4.50	92.3	1.70	13.7	0.00	0.00

surface (See Figure 1b). Wrinkles less than 1 mm high are ignored. Pinching of the skin, where the skin is gathered by the cuff from a deep level up to a superficial peak and back down again within 20 mm, is counted as two wrinkles. The maximum wrinkle height and the sum of all wrinkles greater than 1 mm high found on each mold are compared. Examples of typical pinch and wrinkle profiles are shown in Figure 2. Five healthy adult volunteers with normal skin and muscle tone (medical research center staff members, age 19-46 years, four male, one female) were recruited. Five different cuff/padding configurations (see Table 1) were chosen for comparison. Each configuration was tested on one arm and both

regardless of the number or height of the remaining wrinkles. The wrinkle height sums provide comparisons of both the severity and quantity of wrinkles and pinches greater than 1 mm high. All test results are listed in Table 2 and the five-cuff/limb protection combinations are compared in Figures 3 and 4.

The two-layer elastic sleeves matched to the specific tourniquet cuffs used produced significantly lower maximum wrinkle heights and lower wrinkle height sums than each of the other configurations ($P < 0.01$ for all paired comparisons). On 10 of the 11 limbs tested, the two-layer elastic sleeve had no wrinkles or pinches higher than 1 mm (the minimum detectable height). The four-

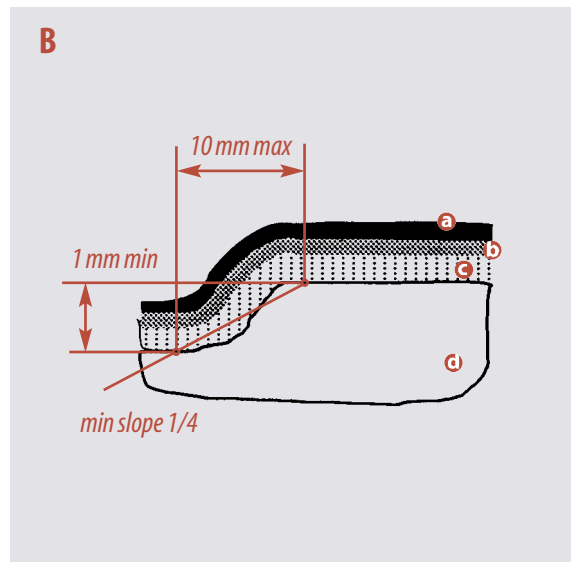
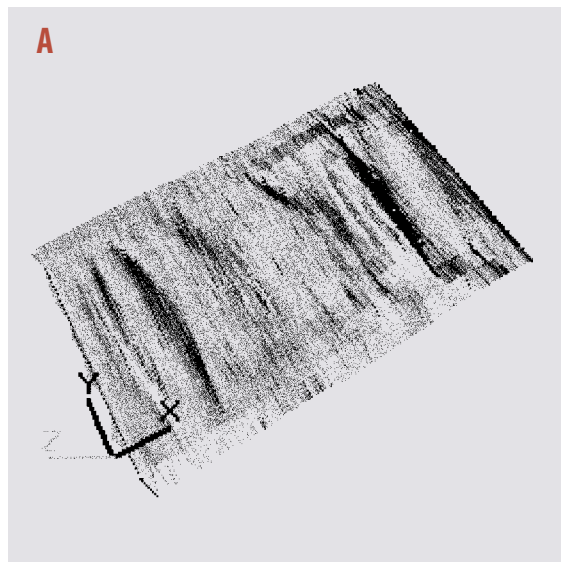

FIGURE 1

(a) Image of typical mold and (b) wrinkle definition parameters

- Ⓐ Cuff
- Ⓑ Padding (if used)
- Ⓒ Mold material
- Ⓓ Skin

thighs of one subject, and one arm and one thigh of the remaining four subjects for a total of 55 trials. A repeated measures study design is used with five treatments and 11 subjects, where each different limb is considered to be a separate subject. To compare maximum wrinkle heights, rank sums are compared using Friedman's statistic, and all possible pairs of configurations are compared using a Student-Newman Keuls' test.⁹ Wrinkle height sums are compared using the same methods.

Results

Maximum wrinkle height represents the single most severe wrinkle or pinch found on a sample

layer stockinette sleeve eliminated wrinkles and pinches higher than 1 mm on two of the 11 limbs tested and was significantly more effective ($P < 0.01$) than all configurations except the two-layer elastic sleeve. Two layers of cotton-cast padding gave a slight reduction in maximum wrinkle height compared to applying the same cuff on bare skin and applying the 'gel' cuff to bare skin ($P < 0.05$), but did not significantly reduce the sum wrinkle and pinch heights in either case ($P > 0.05$). The 'gel' cuff applied on bare skin produced slightly higher maximum wrinkle and pinch heights ($P = 0.05$) with no significant reduction in the sum of wrinkle and pinch heights ($P > 0.05$) compared to a typical cuff (Cuff A) applied on bare skin.

Discussion

Rudolph et al surveyed 44 clinics in Europe concerning over 75,000 procedures involving tourniquet use (adult and pediatric).⁴ Tissue damage was reported in 1.4% of lower limb and 0.4% of upper limb cases (usually reddening with blisters). Many cases involve fluids such as antiseptic flowing under the cuff, but the survey indicates that fluid leakage, excess pressure, excess duration of cuff or a combination of these factors can cause skin damage. Sixty-five percent of the clinics reported using cotton padding material, 20% other types of padding, and 15% no material under the cuff. Choudhary reported a case of friction burns on an adult patient's leg

skin 'ridges' (pinched areas) on cross-sectional CT views of a rabbit hindlimb under two different cuffs. He noted similar ridges in MRI images of a human thigh under tourniquet pressure, but did not analyze these differences in detail.¹⁰ In a brief note on technique, Harland observes that unprotected skin under a cuff can be damaged due to shearing stresses and that stockinette folded back over the cuff is effective as a padding material and in keeping the cuff in position.⁵

In the current study, we use a quantitative method to compare the severity of wrinkling and pinching of the skin in adults under the inflated cuff. The two-layer elastic sleeves were significantly more effective in eliminating wrin-

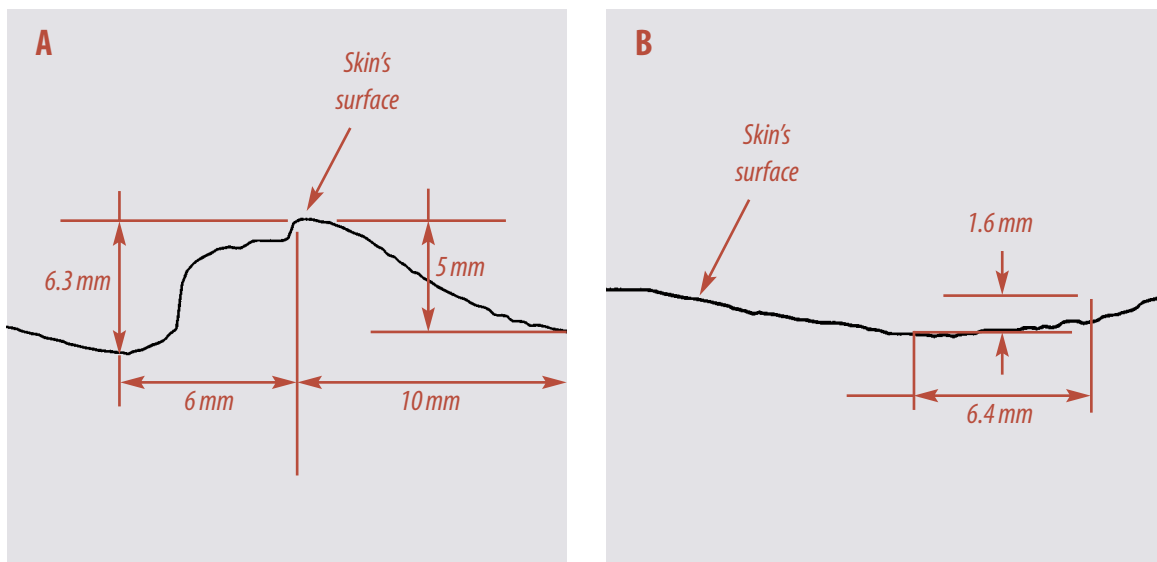

due to the tourniquet cuff sliding distally off the padding material during the procedure (no fluids were found under the cuff in this case).⁶

Present recommended practices for operating room personnel, intended as guidelines adaptable to various practice settings, refer clinicians to cuff manufacturers' recommendations for limb protection.¹ However some manufacturers do not make specific recommendations and refer the clinician to the established protocol at their practice setting. There is little discussion in the literature of pinching of the skin or local high pressure areas and shearing stresses caused by wrinkles in the inflated cuff. Pedowitz qualitatively observed a difference in the limb shape and

kles and pinches than all other types of limb protection. In this study, a specific size of two-layer elastic sleeve was selected for each cuff size, so the sleeves stretched to about 1.1 to 1.6 times their relaxed circumference when applied to limbs within the recommended size range of the cuff. This applies compression of between 5 and 15 mm Hg to the limb, 'artificially' improving the tone of the skin under the cuff and making the skin resistant to being gathered up into a pinch (particularly at the cuff overlap). Although a standard tensor bandage material could be wrapped around the limb to the same effect, the pressure applied to the limb is highly variable depending on operator technique. Such pres-

FIGURE 2

(a) Profile of a large pinch vs
(b) typical small wrinkle

sures could easily be above typical venous pressure of 20 mmHg, leading to venous congestion if the sleeve remains on the patient after the cuff is deflated. For example, Biehl measured pressures under Esmarch bandages used as ankle tourniquets and found standard deviations of 35 to 53 mmHg in multi-operator tests.¹¹

The four-layer stockinette sleeves, used in this study (supplied with the cuffs), were loose or only slightly stretched and applied negligible compression when used on a limb within the size range of the corresponding cuff. These sleeves provide a ‘padding’ effect due to their thick buildup of material (rather than the ‘toning’ effect provided by the two-layer elastic sleeves).

Therefore, this method can be used as a comparison measure only (as used in the current study) and serves the purpose of identifying clear differences between limb protection methods. Due to the wide variety of skin properties found among surgical patients, validation of the mold material’s ‘skin-like’ properties would only apply to a certain percentage of patients and would therefore be of limited value. However, to draw conclusions for clinical practice from the current study, it must be assumed that the relative performance of the various methods is similar on actual skin and over the variety of skin types not fully represented by the healthy volunteers. Although the patient population is not

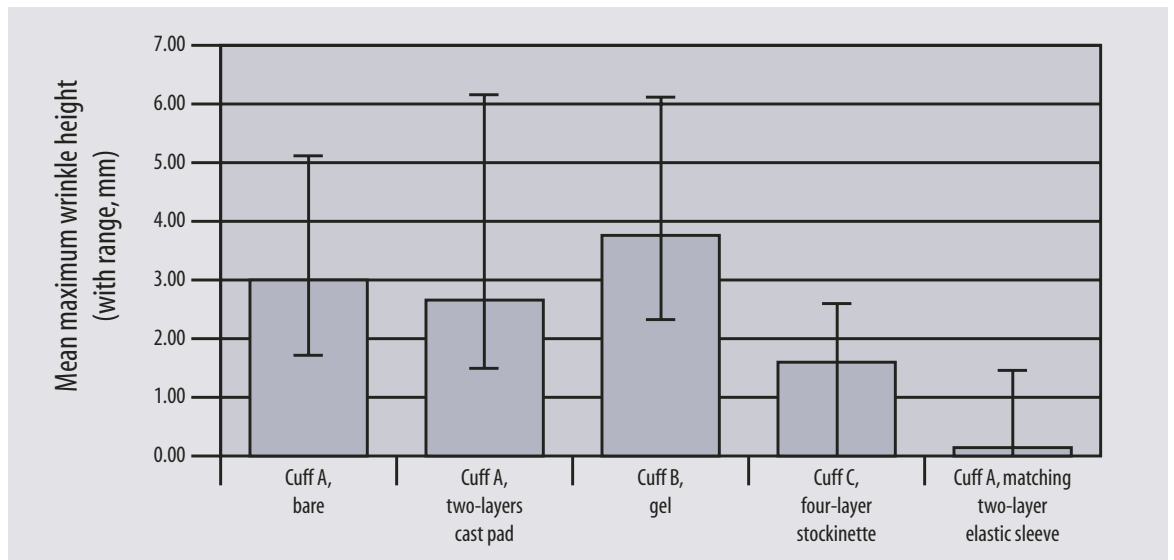

FIGURE 3

Mean maximum wrinkle/pinch heights for common cuff/padding configurations (n=11 trials).

Wrinkling and pinching of the skin is clearly more severe when applying a typical, disposable cuff directly on the patient’s skin, using a two-layer wrap of typical cotton-cast padding under a typical disposable cuff, and using a ‘gel’ cuff directly on the skin. Cast padding may offer some reduction of the maximum pinch or wrinkle height compared to no limb protection or the gel cuff, but the sum of wrinkle and pinch heights is the same among all three methods.

The mold material itself may affect pinching of the skin, and at this stage, no attempt has been made to measure differences in the absolute dimensions of irregularities in the skin surface between actual tourniquet use and the molds.

fully represented by testing healthy adult volunteers in a controlled laboratory setting, this approach allows a repeated measures study design (in which each subject receives all of the treatments being compared, in this case different cuff/limb protection combinations) which is the most powerful way of comparing treatments. Such repeated cuff applications may not be practical in a clinical setting or with patients having certain health conditions. The detection of irregularities is sensitive to the height, slope, and maximum distance parameters chosen (See Figure 1b), and results will change with these parameters. The parameters were adjusted by reviewing each section of a variety of molds and

confirming that all irregularities that would be subjectively identified on the mold as a wrinkle or pinch were recorded by the data processing routine. The chosen parameters were then used on all molds and each section was reviewed during processing.

For future study, an absolute measure of the cuff/skin interface could be made by taking cross sectional images (MRI) of inflated cuffs on limbs and analyzing the wrinkles and pinches using similar criteria to the current study. Clinical observation of the skin condition (pattern of redness and indentation, reports of irritation or rash) of a series of typical patients after tourniquet cuff removal could also be done to make a more representative but less quantitative comparison of limb protection techniques.

Conclusions

There has been a lack of clear guidelines and published studies in the clinical literature referring to proper limb protection technique under tourniquet cuffs. Our hypothesis that some types of cuff/padding combinations will cause substantially less severe wrinkling and pinching of the skin than others is supported by the current comparative measurements of skin surface deformation. Based on a total of 55 trials of five different limb protection types on the upper arms and thighs of five adults, stretched sleeves made of two-layer tubular elastic material and matched to specific tourniquet cuffs produced significantly fewer, less severe pinches and wrinkles in the skin surface than all other padding types tested (maximum $P < 0.01$). When using typical disposable cuffs, wrinkling and pinching were clearly more severe with no padding and with two layers of typical cotton-cast padding compared to both the two-layer tubular elastic and the four-layer loose stockinette sleeves (maximum $P < 0.01$). Cast padding gave only a slight reduction in maximum wrinkle or pinch height ($P < 0.05$) and did not reduce the overall amount of wrinkling significantly ($P > 0.05$) compared to applying the same cuff on bare skin. A new disposable cuff with built-in gel padding applied on the bare skin was worse or not significantly dif-

Recommendations for tourniquet use on arms and thighs of adult patients

In view of the results of this study and prior recommendations in the relevant clinical literature as described in this article, the following summary of recommendations for applying limb protection and tourniquet cuffs at arm and thigh locations on adults is presented:

1. Select the widest cuff suitable for the selected limb location and the surgical procedure, and if possible use a contoured cuff able to match the taper of the limb at this location;¹⁻³
2. If possible, select a limb protection sleeve specifically matched to the selected cuff. If such a sleeve is not available, apply two layers of tubular stockinette or tubular elastic bandage, sized such that it is stretched when applied to the limb at the cuff location and such that the compression applied by the stockinette or elastic bandage is less than venous pressure (~ 20 mmHg) and less than the pressure of a snugly applied cuff.⁸
3. Apply the tourniquet cuff snugly over the limb protection sleeve;¹
4. Using the applied cuff, measure the patient's limb occlusion pressure (LOP), and set the tourniquet pressure at LOP plus a safety margin, recommended to be 40, 60, or 80 mmHg (for LOP of less than 130, 131-190, and greater than 190 mmHg respectively) for a normotensive patient having a normal limb;²
5. Exsanguinate by elastic bandage or elevation, as appropriate for the patient and procedure;¹
6. Inflate the tourniquet cuff and monitor the tourniquet during use, as recommended by the manufacturer;¹
7. In the event that arterial blood flow is observed past the tourniquet cuff, increase tourniquet pressure in 25 mmHg increments until blood flow stops;³
8. Minimize tourniquet time;¹
9. Immediately upon deflation of the tourniquet, remove the cuff and sleeve from the limb.

ferent than the typical disposable cuff applied over either bare skin or cast padding.

Acknowledgements

The authors would like to thank Kathy Bailey RN, Michael Jameson, Ken Glinz, and the volunteer subjects for their assistance with this study.

References

1. AORN (Association of periOperative Registered Nurses). "Recommended practices for use of the pneumatic tourniquet." In: *Standards, Recommended Practices, and Guidelines*. Denver: Association of Operating Room Nurses, Inc, 2000: 305-309.

Unfallchirurgie. 1990; 16(5): 244-51 (Abstract in English & German, article in German).

5. Harland P, Lovell ME. "An alternative method of tourniquet padding." *Annals Royal College of Surgery*. England 1994; 76(2):107.
6. Choudhary S, Koshy C, Ahmed J, Evans J. "Friction burns to thigh caused by tourniquet." *British Journal of Plastic Surgery*. 1998; 51:142-3.
7. *Tourniquet Safety Home Study Guide*. Warsaw, IN: Zimmer Inc. Denver: Education Design, Inc; 1997.
8. Tredwell SJ, Wilmlink M, Inkpen K, McEwen J. "Pediatric Tourniquets: Analysis of

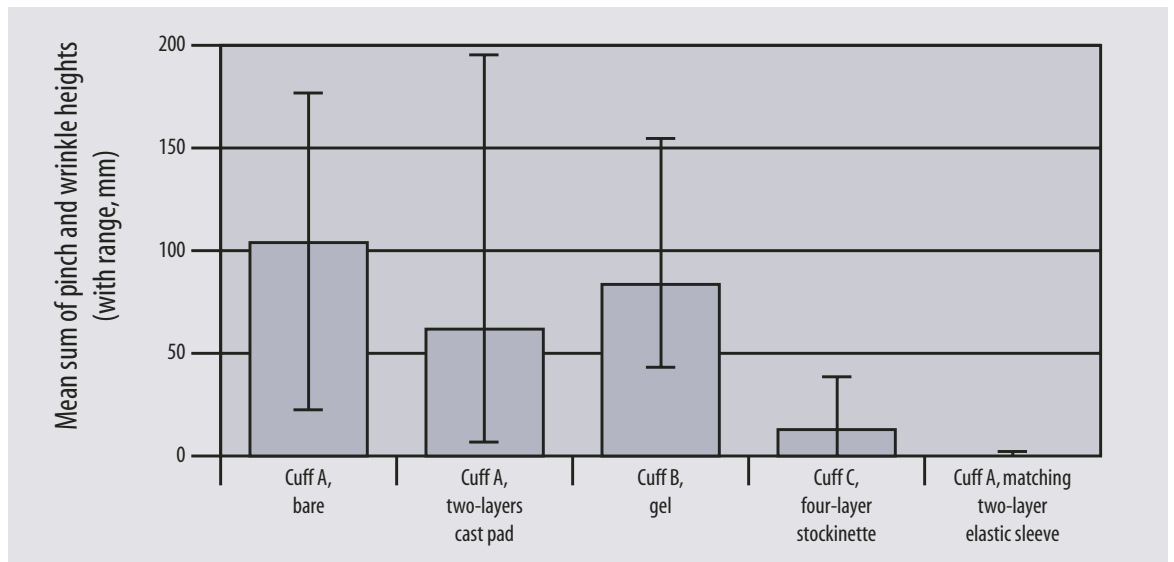

FIGURE 4

Mean sums of wrinkle and pinch heights for common cuff/padding configurations (n=11 trials).

2. McEwen JA, Kelly DL, Jordanowski T, Inkpen K. "Tourniquet safety in lower leg applications: Limb occlusion pressure measurement and a wide contoured cuff allow lower cuff pressure." *Orthopaedic Nursing*. 21(5); Sept/Oct 2002 (in press).
3. Pedowitz RA, Gershuni DH, Botte MJ, Kuiper S, Rydevik BL, Hargens AR. "The use of lower tourniquet inflation pressures in extremity surgery facilitated by curved and wide tourniquets and an integrated cuff inflation system." *Clin Orthop*. 287 (Feb. 1993) 237-44.
4. Rudolph H, Gartner J, Studtmann V. "Skin lesions after utilization of a tourniquet."

cuff/limb interface, current practice, and guideline for use." *J Ped Orthop*. 21(5); Sept/Oct 2001: 671-676.

9. Glantz, SA. *Primer of Biostatistics*. 4th ed. New York: McGraw-Hill; 1997.
10. Pedowitz RA, Rydevik BL, Gershuni DH, Hargens AR. "An animal model for the study of neuromuscular injury induced beneath and distal to a pneumatic tourniquet." *Journal of Orthopaedic Research*. 1990;8(6):899-908.
11. Biehl WC 3rd, Morgan JM, Wagner FW Jr, Gabriel RA. "The safety of the Esmarch tourniquet." *Foot & Ankle*. 1993; 14(5): 278-83.